

PERFORMANCE
MADE
SMARTER

Product manual

2224

Valve controller



EAC

UK
CA

CE

TEMPERATURE | I.S. INTERFACES | COMMUNICATION INTERFACES | MULTIFUNCTIONAL | ISOLATION | DISPLAY

No. 2224V104-UK
From serial no.: 211096001

PR
electronics

6 Product Pillars

to meet your every need

Individually outstanding, unrivalled in combination

With our innovative, patented technologies, we make signal conditioning smarter and simpler. Our portfolio is composed of six product areas, where we offer a wide range of analog and digital devices covering over a thousand applications in industrial and factory automation. All our products comply with or surpass the highest industry standards, ensuring reliability in even the harshest of environments and have a 5-year warranty for greater peace of mind.



Our range of temperature transmitters and sensors provides the highest level of signal integrity from the measurement point to your control system. You can convert industrial process temperature signals to analog, bus or digital communications using a highly reliable point-to-point solution with a fast response time, automatic self-calibration, sensor error detection, low drift, and top EMC performance in any environment.



We deliver the safest signals by validating our products against the toughest safety standards. Through our commitment to innovation, we have made pioneering achievements in developing I.S. interfaces with SIL 2 Full Assessment that are both efficient and cost-effective. Our comprehensive range of analog and digital intrinsically safe isolation barriers offers multifunctional inputs and outputs, making PR an easy-to-implement site standard. Our backplanes further simplify large installations and provide seamless integration to standard DCS systems.



We provide inexpensive, easy-to-use, future-ready communication interfaces that can access your PR installed base of products. All the interfaces are detachable, have a built-in display for readout of process values and diagnostics, and can be configured via push-buttons. Product specific functionality includes communication via Modbus and Bluetooth and remote access using our PR Process Supervisor (PPS) application, available for iOS and Android.



Our unique range of single devices covering multiple applications is easily deployable as your site standard. Having one variant that applies to a broad range of applications can reduce your installation time and training, and greatly simplify spare parts management at your facilities. Our devices are designed for long-term signal accuracy, low power consumption, immunity to electrical noise and simple programming.



Our compact, fast, high-quality 6 mm isolators are based on microprocessor technology to provide exceptional performance and EMC-immunity for dedicated applications at a very low total cost of ownership. They can be stacked both vertically and horizontally with no air gap separation between units required.



Our display range is characterized by its flexibility and stability. The devices meet nearly every demand for display readout of process signals and have universal input and power supply capabilities. They provide a real-time measurement of your process value no matter the industry and are engineered to provide a user-friendly and reliable relay of information, even in demanding environments.

Valve controller 2224

Contents

| | |
|--|----|
| How to dismantle system 2200 | 2 |
| Applications | 3 |
| Technical characteristics | 3 |
| Mounting | 3 |
| Order | 4 |
| Electrical specifications | 4 |
| Block diagram | 5 |
| Timing diagram | 6 |
| DIP-switch programming | 6 |
| Wiring diagrams for joystick / potentiometer input | 8 |
| Wiring diagrams for DC current input | 9 |
| Wiring diagrams for DC voltage input | 10 |
| Technical description | 11 |
| Routing diagram | 12 |
| Configuration / operating the function keys | 13 |
| Document history | 15 |

How to dismantle system 2200

Picture 1:

The back panel of the device is detached from the housing by way of a screwdriver.

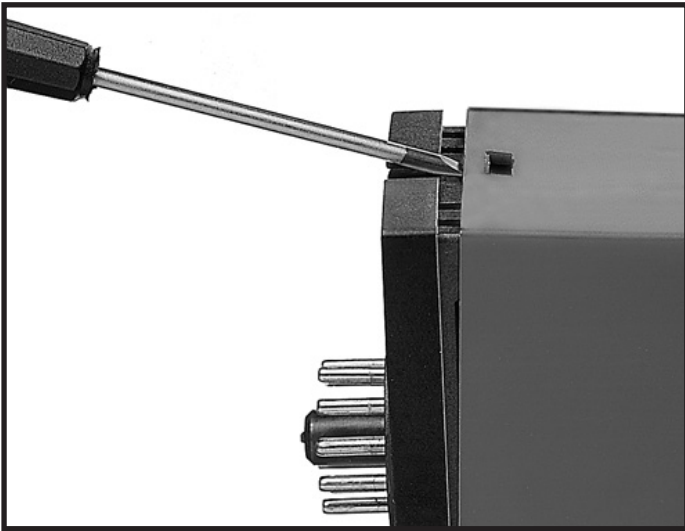

Picture 2:

After this, the back panel can be pulled out together with the PCB, but please notice the position of the PCB as there is a number of different positions in the house. Do not pull the wires unnecessarily, instead pull the PCB. Switches and jumpers can now be moved.

When assembling the back plate and housing, please make sure no wires are stuck.

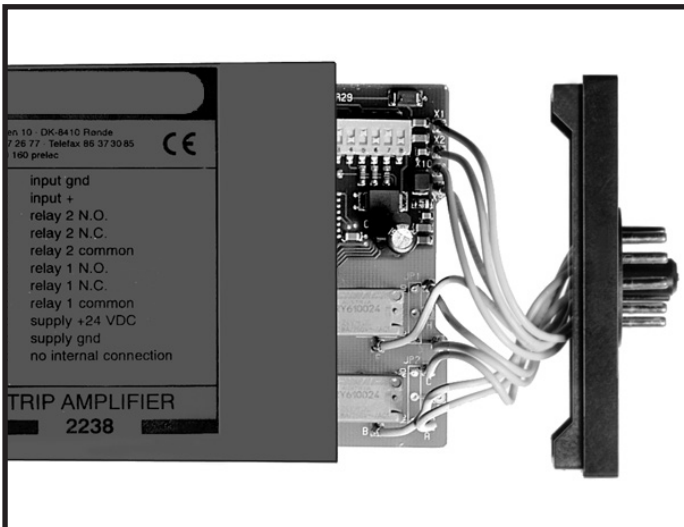

Valve controller 2224

- Front-programmable
- mA, V, and Ω -programmable input
- Ramp times, jump values, reversal, chopper frequency, and deadband
- 3-digit LED display shows I_{valve} % value
- 1 or 2 channels
- Modulated current output for proportional valve

Applications

- Control and regulation of single or double-coil hydraulic and pneumatic proportional valves.
- The unit is used for accurate oil flow regulation, linear soft acceleration and deceleration, modulated output signal, and programmable deadband.
- Is highly suitable for joystick regulation of A/B movements.

Technical characteristics

- The 2224 Valve Controller is a microprocessor-based unit containing ramp functions for soft start and stop and jump functions thus avoiding deadband at start and changes between A & B valves.
- The user interface of the valve controller consists of three pushbuttons and a 3-digit LED display. By using these, output currents, ramp times, jump values, chopper frequency, reversal, deadband, and on/off functions are changed.
- During operation the display shows the present output signal as a % of the I_{valve}.
- All parameters are protected against unauthorised changes with a password.
- Changes between A and B valves can be made in two ways. By way of function 1, the A valve is chosen when +V_{supply} is applied to terminal 2. By way of function 2, changes between A/B valves take place automatically according to the value of the input signal (no signal on terminal 2).
- The output current is enabled / disabled by a digital controlling signal. Please note that the output current is disconnected until +V_{supply} is applied to terminal 3.
- Programmable current or voltage input for standard signals acc. to order schedule, joystick / potentiometer or a special non-programmable input.
- Digital inputs for external control functions.
- A pulsating current output prevents the connected valve from sticking.
- Optional programming of the modulation frequency (PWM) between 8 and 400 Hz.
- The internal measuring and control circuit ensures that the mean current never exceeds the entered I_{valve}.
- If the peak current exceeds 7 A the output will be disabled.

Mounting

- Mounting for a standard 11-pole socket which can be adapted for DIN rail or plate use with PR's 7023 adaptor and 7024 mounting keying

Order

| Type | Input | Supply | Option |
|------|----------------------------|----------|------------------------|
| 2224 | 0...20 mA : A | 12 V : 1 | Single valve (A) : A |
| | 4...20 mA : B | 24 V : 2 | Double valve (A/B) : B |
| | 0...1 V : C | | |
| | 0.2...1 V : D | | |
| | 0...10 V : E | | |
| | 2...10 V : F | | |
| | ±10 V potentiometer : G | | |
| | 0...10 V potentiometer : H | | |

Electrical specifications

Environmental conditions

| | |
|---------------------------------|----------------------|
| Operating temperature | -20°C to +60°C |
| Humidity. | < 95% RH (non-cond.) |
| Protection degree | IP50 |

Mechanical specifications

| | |
|------------------------------|---|
| Dimensions (HxWxD) | 80.5 x 35.5 x 84.5 mm (D is without pins) |
| Weight approx. | 130 g |

Common specifications

| | |
|---|------------------------------------|
| Supply voltage (nom. 12 V / 24 V) | 9.6...28.8 VDC |
| Internal power dissipation | 2 W / 24 V 1,8 W / 12 V |
| Programming | Front-programmable |
| Updating time | 30 ms |
| Temperature coefficient. | 0.01%/°C |
| Accuracy. | Better than 0.2% of selected range |
| Linearity error | 0.2% |
| EMC immunity influence | < 2% of span |

Input specifications

Current input

| | |
|-----------------------------|----------------------|
| Measurement range | 0...20 and 4...20 mA |
| Input resistance | 50 Ω + PTC (54 Ω) |

Voltage input

| | |
|-----------------------------|-------------------------------------|
| Measurement range | 0...1, 0.2...1, 0...10 and 2...10 V |
| Input resistance | 10 MΩ |

Potentiometer input

| | |
|---|------------------------------|
| Potentiometer min...max.. | 0...10 V or ±10 V / 10 kΩ |
| External potentiometer. | 1 kΩ ≤ potentiometer ≤ 10 kΩ |
| Operation / shutdown. | PNP / 2.2 kΩ, 12 / 24 V |
| I _{max.1} & I _{max.2} | PNP / 2.2 kΩ, 12 / 24 V |
| A / B channel | PNP / 2.2 kΩ, 12 / 24 V |
| Deadband | 0...99.9% of input span |

Output specifications

| | |
|-----------------------------|---|
| Output voltage | Supply voltage-0.5 V (max.) |
| Output current | 3000 mA mean |
| Current peak | 7 A |
| Reference voltage | 10 VDC (A valve) ±10 VDC (A & B valve) |
| Ramp up & down. | Time 0...10.0 s |
| PWM frequency. | 8...400 Hz in steps of 1 Hz |

Of span = Of the presently selected range

Observed authority requirements

EMC 2014/30/EU & UK SI 2016/1091
 RoHS 2011/65/EU & UK SI 2012/3032
 EAC TR-CU 020/2011

Block diagram

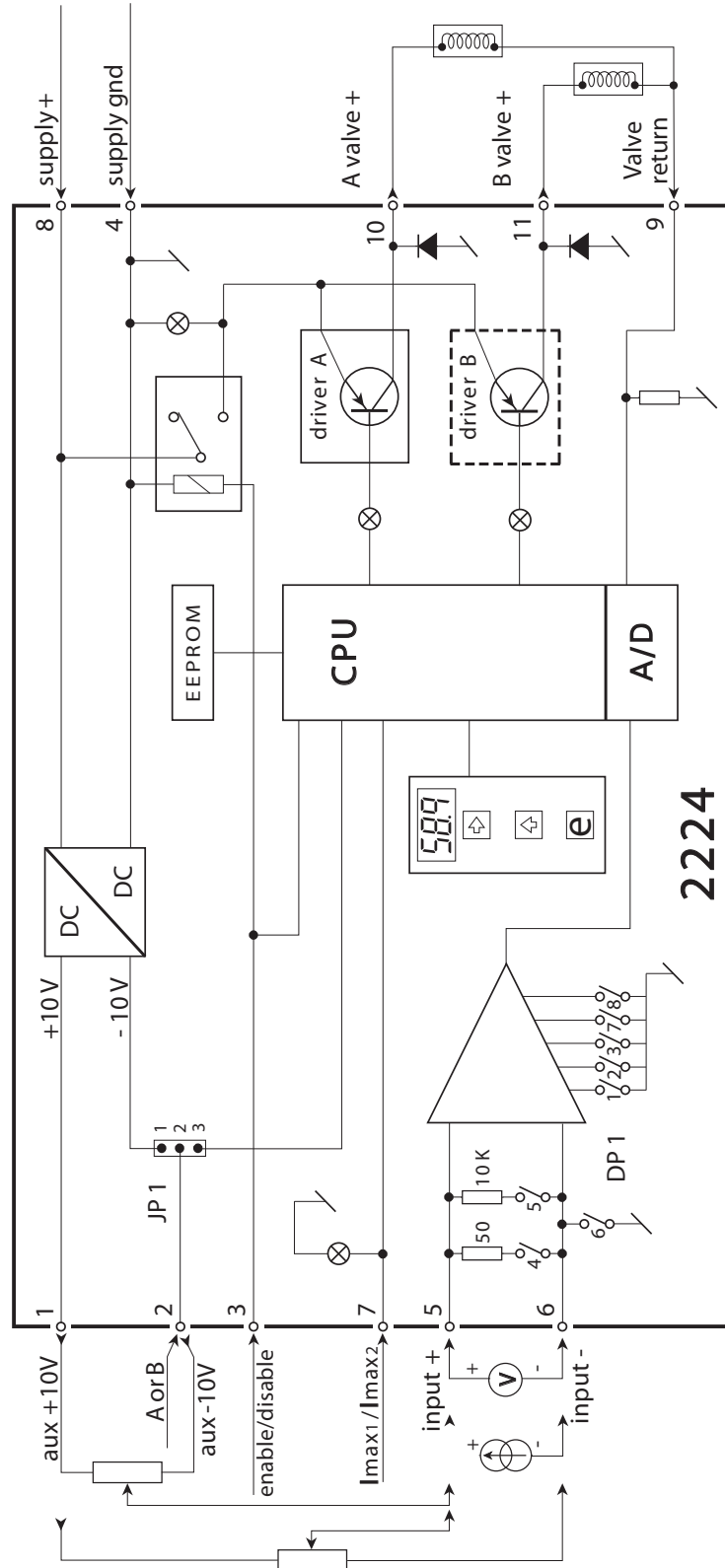

Timing diagram

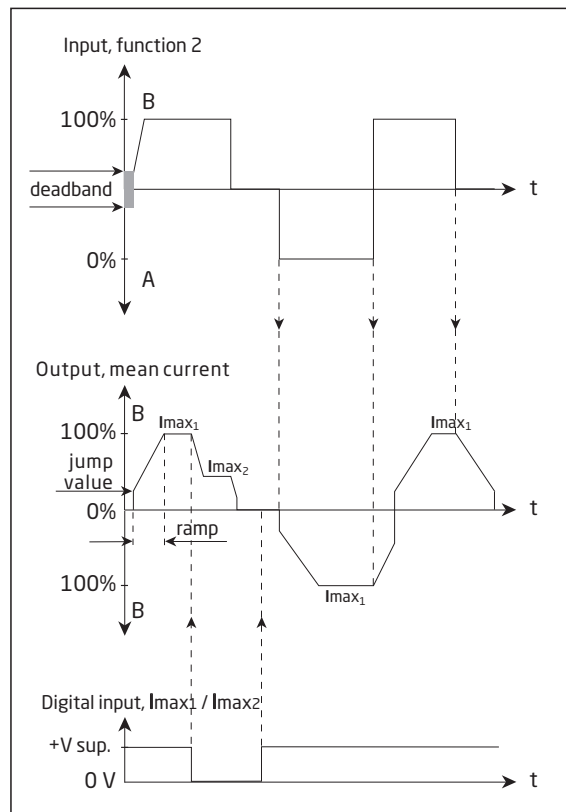

DIP-switch programming

Input signal and function are chosen via the DIP-switch setting.

Function 1:









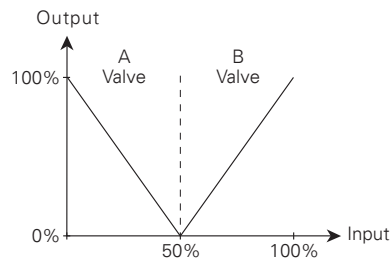





Single and double valve control. By double valve control, A valve is chosen by applying +Vsupply to terminal 2.

Function 2:

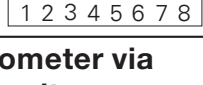
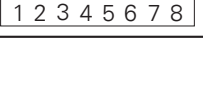
Double valve control with automatic change between A and B valves (no signal on terminal 2).

Input: 0...50% = A valve 100...0%.
 Input: 50...100% = B valve 0...100%.



| Signal input: | Function 1: | Function 2: | JP1 pos.: |
|--|--|--|-----------|
| 0...20 mA | DP1 * On  Off | DP1 * On  Off | 2-3 |
| 4...20 mA | DP1 * On  Off | No function | 2-3 |
| 0...1 V | DP1 * On  Off | DP1 * On  Off | 2-3 |
| 0.2...1 V | DP1 * On  Off | No function | 2-3 |
| 0...10 V | DP1 * On  Off | DP1 * On  Off | 2-3 |
| 2...10 V | DP1 * On  Off | No function | 2-3 |
| -10...+10 V | DP1 * On  Off | DP1 * On  Off | 2-3 |
| Joystick / potentiometer via internal reference voltage | | | |
| 0...10 V | DP1 (*) On  Off | DP1 (*) On  Off | 2-3 |
| -10...+10 V | No function | DP1 (*) On  Off | 1-2 |
| Input: | Grounded | Differential | |
| * | DP1 On  Off | DP1 On  Off | ---- |

Wiring diagrams for joystick / potentiometer input

Double valve control (A/B valves) from +/-10 VDC reference supply.
 DIP-switch programming:
 Function 2.

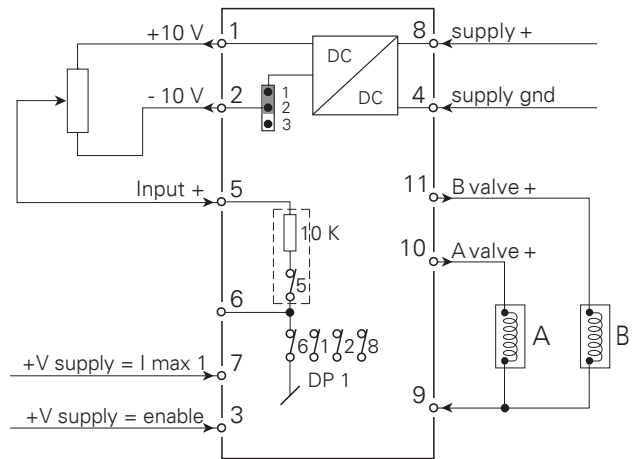

Double valve control (A/B valves) from +10 VDC reference supply.
 DIP-switch programming:
 Function 1 or
 Function 2.

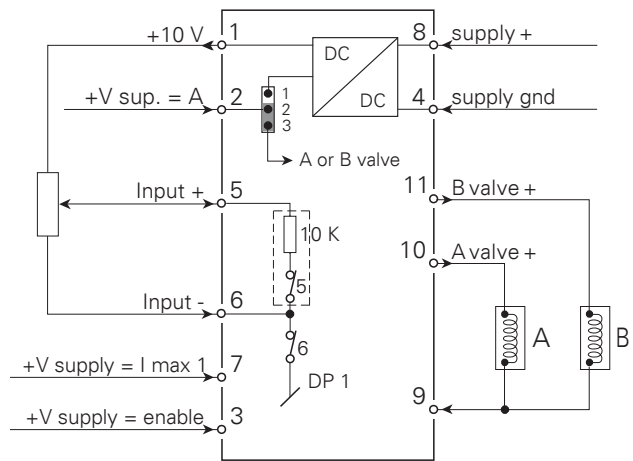

Single valve control from +10 VDC reference supply.
 DIP-switch programming:
 Function 1.

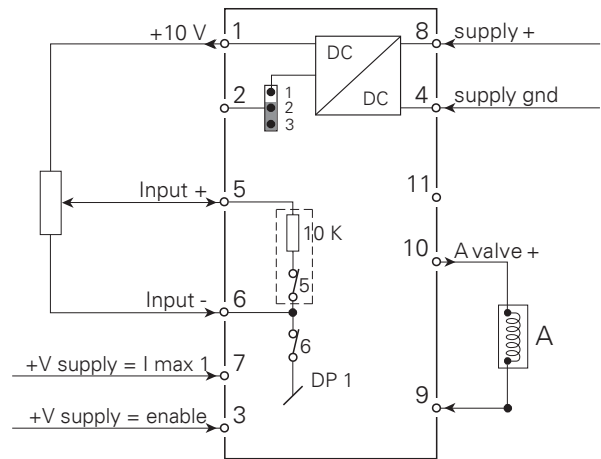

Wiring diagrams for DC current input

Double valve control (A/B valves) from a 0...20 mA input signal.
 DIP-switch programming:
 Function 1 or
 Function 2.

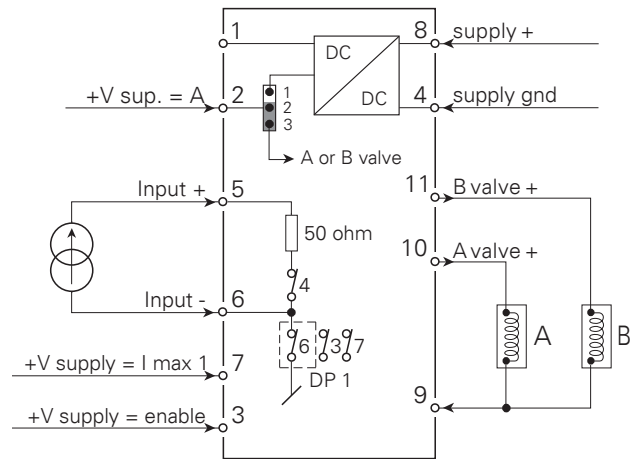

Single valve control from a 4...20 mA input signal.
 DIP-switch programming:
 Function 1.

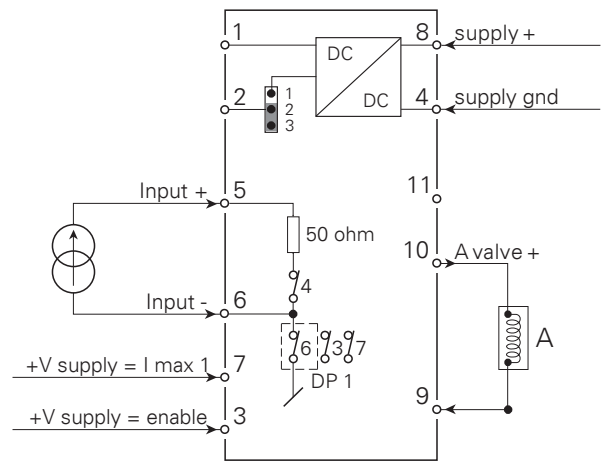

Wiring diagrams for DC voltage input

Double valve control (A/B valves) from a 0...1 VDC input signal.

DIP-switch programming:

Function 1 or

Function 2.

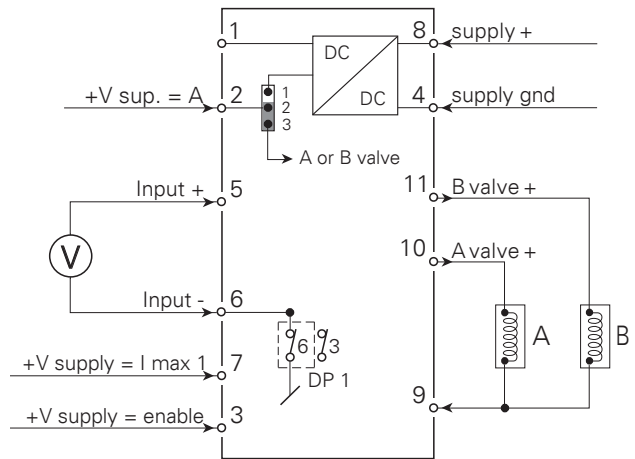

Single valve control from a 0...1 VDC input signal.

DIP-switch programming:

Function 1.

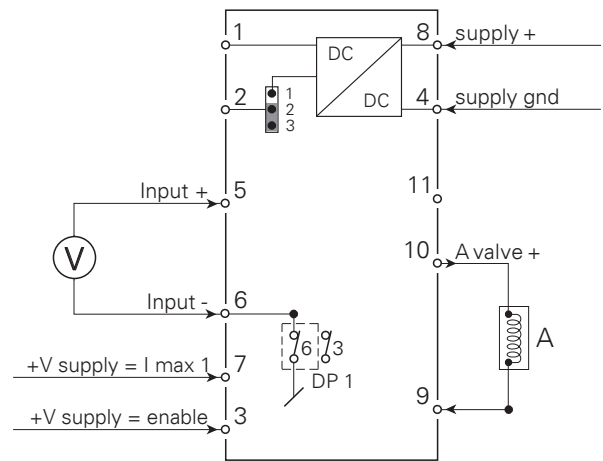

Double valve control (A/B valves) from a -10...+10 VDC input signal.

DIP-switch programming:

Function 1 or

Function 2.

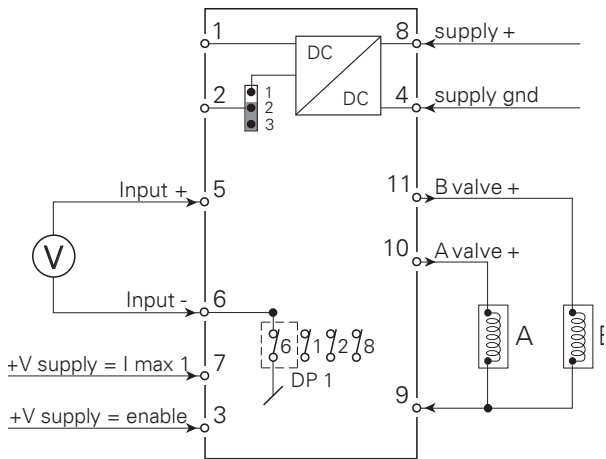

Technical description

- To prevent programming during operation, two safety measures have been included: The correct password (030) must be entered in menu [PAS], and the output must give no signal (000 must be displayed). This is achieved by disconnecting +Vsupply on terminal 3.
- The 2224 Valve Controller can be controlled by a joystick / potentiometer using the internal +10 V and -10 V supply, or a process current / voltage signal. For process signals the differential amplifier (DP1 switch 6 off) will reduce disturbances from noisy signals. Joysticks / potentiometers are connected single-ended (grounded), and it is possible to connect a 10 k Ω load resistor (DP1 switch 5 on), providing a minimum potentiometer load current.
- A switch between A and B valves can be made in two ways. By way of function 1, the A valve is chosen when +Vsupply is applied to terminal 2. By way of function 2, changes between A/B valves are made automatically according to the value of the input signal (no signal on terminal 2). Input: 0...50% = A valve 100...0%. Input: 50...100% = B valve 0...100%.
- When connecting the output to a solenoid please ensure that the peak valve current = Vsupply / Rsolenoid does not exceed 7A.
- A deadband can be programmed to avoid unintentional activation of the valve in connection with e.g. an inaccurate neutral position of joysticks. The deadband introduces a threshold which must be exceeded before any output activity will take place.
- The spring response (bias) can be adjusted to account for the valve seat travel before oil flow.
- Two current limits can be programmed (Imax1 & Imax2) for limit stop detection featuring slow motion before stop. The active current limit (Imax1 & Imax2) is selected by the PNP input signal on terminal 7.
- The 2224 Valve Controller **complies with EMC data only** when shielded cabling is used and the shield is connected to supply ground.

Routing diagram

Programming

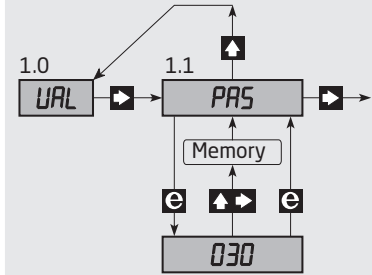

e Go to entry menu / Leave menu without changes.

▶ Next digit or point.

▲ Change of parameter.

To store changes press **▶▲** simultaneously.

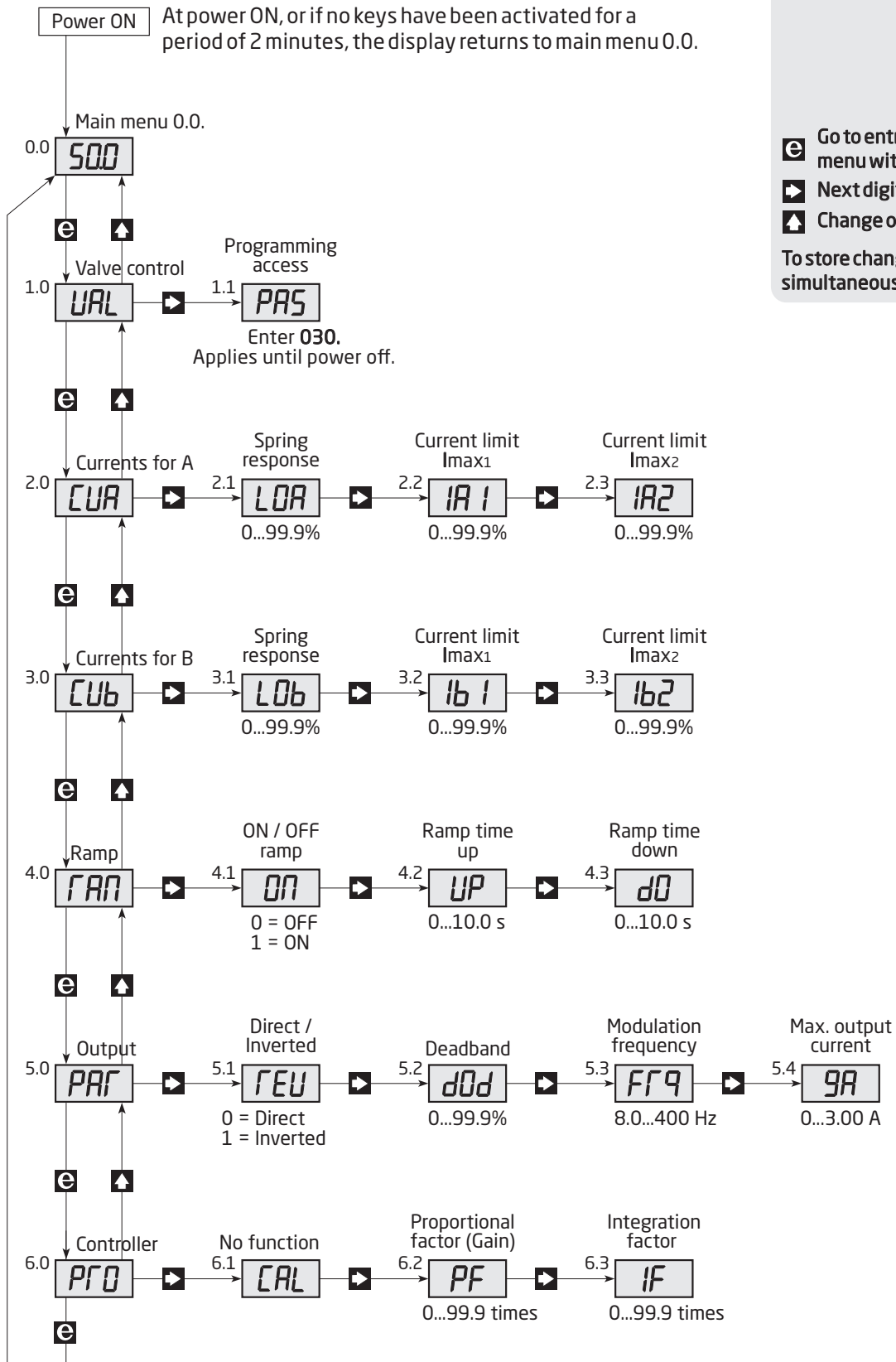

Configuration / operating the function keys

Documentation for routing diagram

General

The configuration is menu-controlled. The main menus are numbered in level 0 (x.0), and the submenus are numbered in level 1 (x.1 to x.4). Each submenu has an accompanying entry menu. The menus are structured in such a way that the menus most frequently used are closer to the default menu 0.0. Please note that programming is only possible when submenu 1.1 PAS has the value 030.

All changes are not permanently saved in the EEPROM, until you return to menu 0.0.

Menus and submenus are selected by the 3 function keys **▶**, **▲**, and **◀** as outlined in the routing diagram.

Activating **◀** in the submenu will display the current value in the entry menu.

In entry menus, the digit that can be changed will flash.

Active digit position is shifted by the **▶** key, and the value is changed by the **▲** key.

In parameter selection menus you switch between the parameters by using the **▲** key.

To store changes temporarily press **▶▲** simultaneously.

To store changes permanently go to menu 0,0.

To return to the previous menu without changing the parameters - press **◀**.

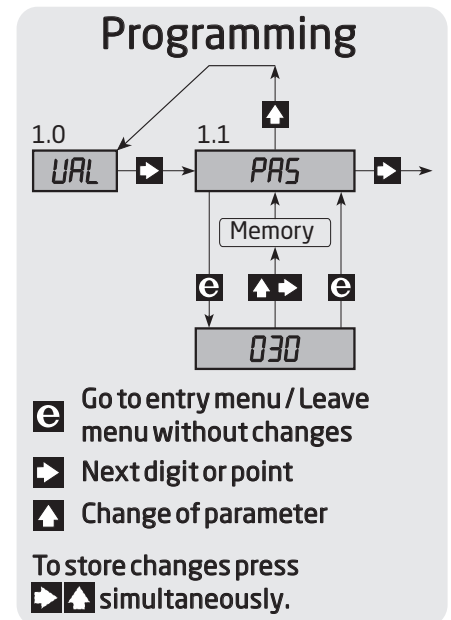

0.0. Default - Output percentage value of I_{valve} is displayed

At power ON, or if no keys have been activated for a period of 2 minutes, the display returns to default.

1.0 VAL - Enter password

1.1 PAS - Programming access

Accepted password is valid until power off.
The password is 030.

2.0 CUA - Setting of currents for A valve

2.1 LOA - Spring response for A valve

The parameter is entered as a percentage of the I_{valve}.
Valid selections are 0...99.9%.

2.2 IA1 - Current limit I_{max1}

The parameter is entered as a percentage of the I_{valve}.
Valid selections are 0...99.9%.

2.3 IA2 - Current limit I_{max2}

The parameter is entered as a percentage of the I_{valve}.
Valid selections are 0...99.9%.

3.0 CUB - Setting of currents for B valve

Please see the setup of the A valve (2.0 CUA).

4.0 RAN - Setting of ramp parameters

4.1 ON - Selection of on/off ramp

1 = ramp enable, 0 = ramp disable.
Valid selections are 0 or 1.

4.2 UP - Setting of ramp time up

The ramp time is set in seconds.
Valid selections are 0...10 s.

4.3 DO - Setting of ramp time down

The ramp time is set in seconds.
Valid selections are 0...10 s.

5.0 PAR - Setting of parameters for output

5.1 REV - Selection of direct / inverted output

0 = direct, 1 = inverted.
Valid selections are 0 or 1.

5.2 DOD - Setting of deadband for e.g. joystick

The parameter is entered as a percentage of the input span.
Valid selections are 0...99.9%.

5.3 FRQ - Setting of modulation frequency for output current

The frequency is set in Hz.
Valid selections are 8...400 Hz.

5.4 GA - Setting of Ivalve

The parameter is set in Ampere - with two decimals.
Valid selections are 0...3.00 A

6.0 PRO - Setting of proportional controller

6.1 PF - Setting of proportional factor (Gain)

6.2 If - Setting of integrating factor

At delivery PF is set at 0.15 and IF at 0.5. These settings will work well for most valves but may have the drawback that it will take too long before the valve reacts.

In order to optimise the control parameters the following "rule-of-thumb" can be applied (all other parameters must be set correctly).

1. Connect a DC-coupled oscilloscope directly across the coil.
2. Set IF at 0.00.
3. Increase PF until the curve on the oscilloscope starts oscillating constantly.
4. Set PF at half of the above value.
5. Increase IF until the curve on the oscilloscope starts oscillating constantly.
6. Set IF at half of the above value.

The control parameters PF and IF can now be fine-tuned using the found values. Lower values will slow the valve's reaction time but eliminate any overshoot.

Document history

The following list provides notes concerning revisions of this document.

| Rev. ID | Date | Notes |
|----------------|-------------|--------------|
| 104 | 2232 | UKCA added. |

We are near you, *all over the world*

Our trusted red boxes are supported wherever you are

All our devices are backed by expert service and a 5-year warranty. With each product you purchase, you receive personal technical support and guidance, day-to-day delivery, repair without charge within the warranty period and easily accessible documentation.

We are headquartered in Denmark, and have offices and authorized partners the world over. We are a local business

with a global reach. This means that we are always nearby and know your local markets well.

We are committed to your satisfaction and provide PERFORMANCE MADE SMARTER all around the world.

For more information on our warranty program, or to meet with a sales representative in your region, visit prelectronics.com.

Benefit today from *PERFORMANCE MADE SMARTER*

PR electronics is the leading technology company specialized in making industrial process control safer, more reliable and more efficient. Since 1974, we have been dedicated to perfecting our core competence of innovating high precision technology with low power consumption. This dedication continues to set new standards for products communicating, monitoring and connecting our customers' process measurement points to their process control systems.

Our innovative, patented technologies are derived from our extensive R&D facilities and from having a great understanding of our customers' needs and processes. We are guided by principles of simplicity, focus, courage and excellence, enabling some of the world's greatest companies to achieve PERFORMANCE MADE SMARTER.